

Mounting

You have the option to use the following mounting template to mark, and then drill two 3/16" (0.1875") holes for the mounting anchors.

To install and mount the Paging Server:

1. Install the mounting anchors in the holes, and position the Paging Server mounting holes over the anchors.
2. Use the two #6 sheet metal screws to secure the Paging Server onto the mounting surface.

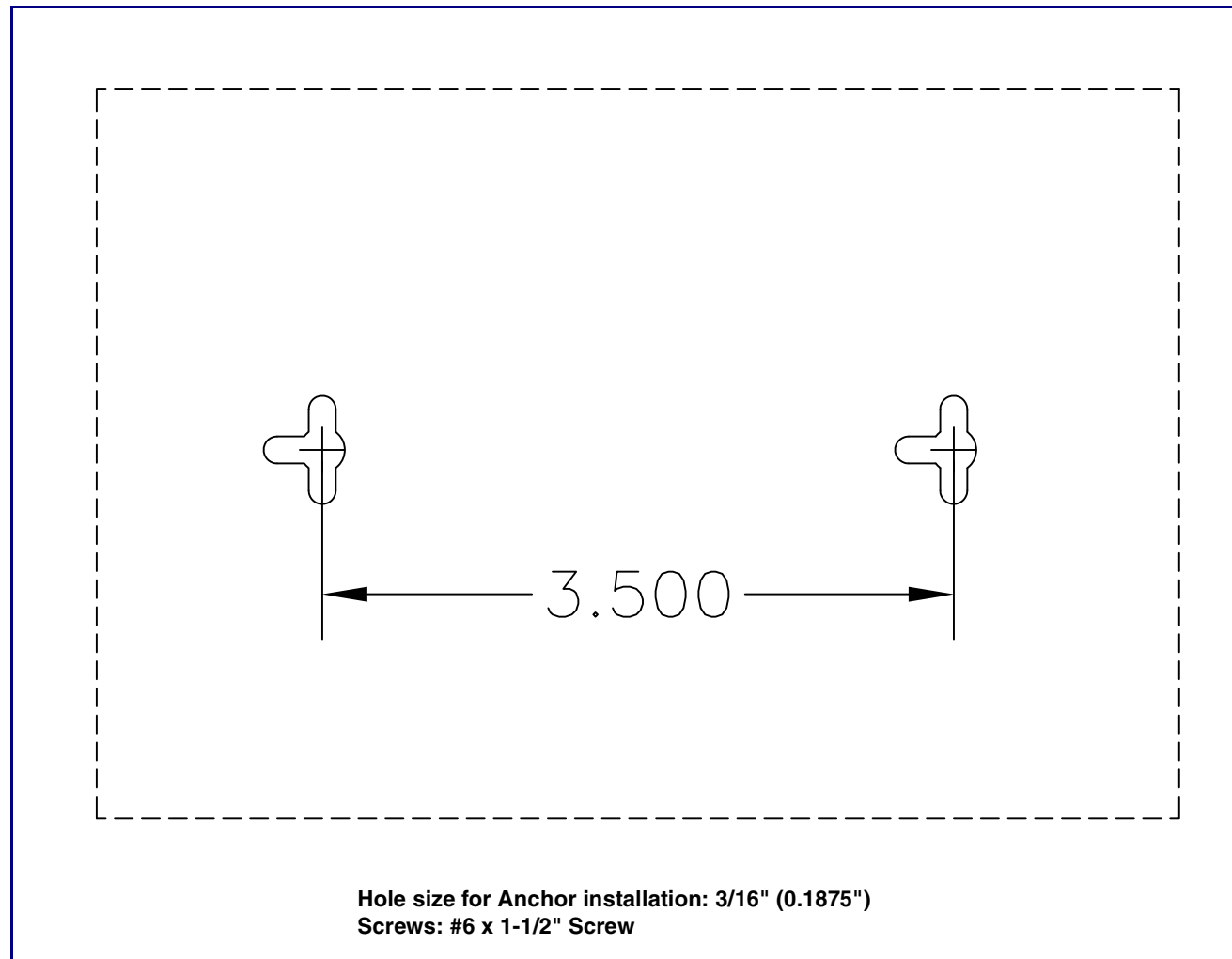

Contacting CyberData

Corporate Headquarters

CyberData Corporation
3 Justin Court
Monterey, CA 93940, USA

Phone: 831-373-2601
Fax: 831-373-4193
www.CyberData.net

Sales: (831) 373-2601 ext. 334
Support: 831-373-2601 ext. 333
Web: <http://www.cyberdata.net/support/contactsupportvoip.html>
RMA Dept: (831) 373-2601 ext. 136
Email: RMA@CyberData.net
RMA Status: <http://www.cyberdata.net/support/rmastatus.html>

Warranty and RMA information is available at the following website:
<http://www.cyberdata.net/support/warranty/index.html>

The VoIP Paging Server enables access to existing paging speakers through a VoIP phone system. This interface uses a standard paging amplifier, and supports paging to multiple zones from a VoIP phone.

Product Specifications

| | |
|-----------------------|---------------------------|
| Regulatory Compliance | FCC Class A, UL 60950, CE |
| Power Requirement | PoE or +48VDC |
| LAN Speed | 10/100 Mbps |
| Protocol | SiP compliant |
| Part Number | 010878 |
| Dimensions | 6.11"L x 4.05"W x 1.15" H |
| Weight | 1.2 lbs. |



Getting Started

- Be sure that you have received all the parts described in the [Parts List](#) section.
- Download the *VoIP Paging Server Operations Guide* at:
<http://www.cyberdata.net/products/voip/digitalanalog/pagingserver/docs.html>

Parts List

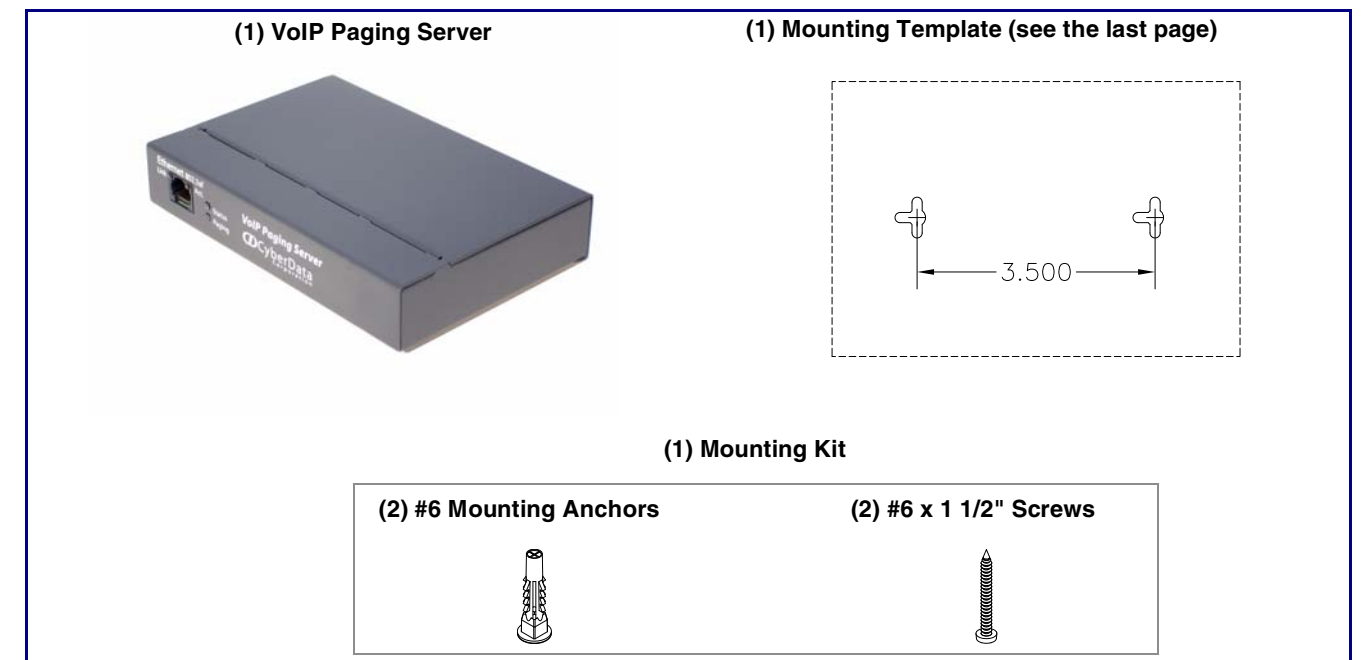

Typical Paging System Setup Using the Paging Server

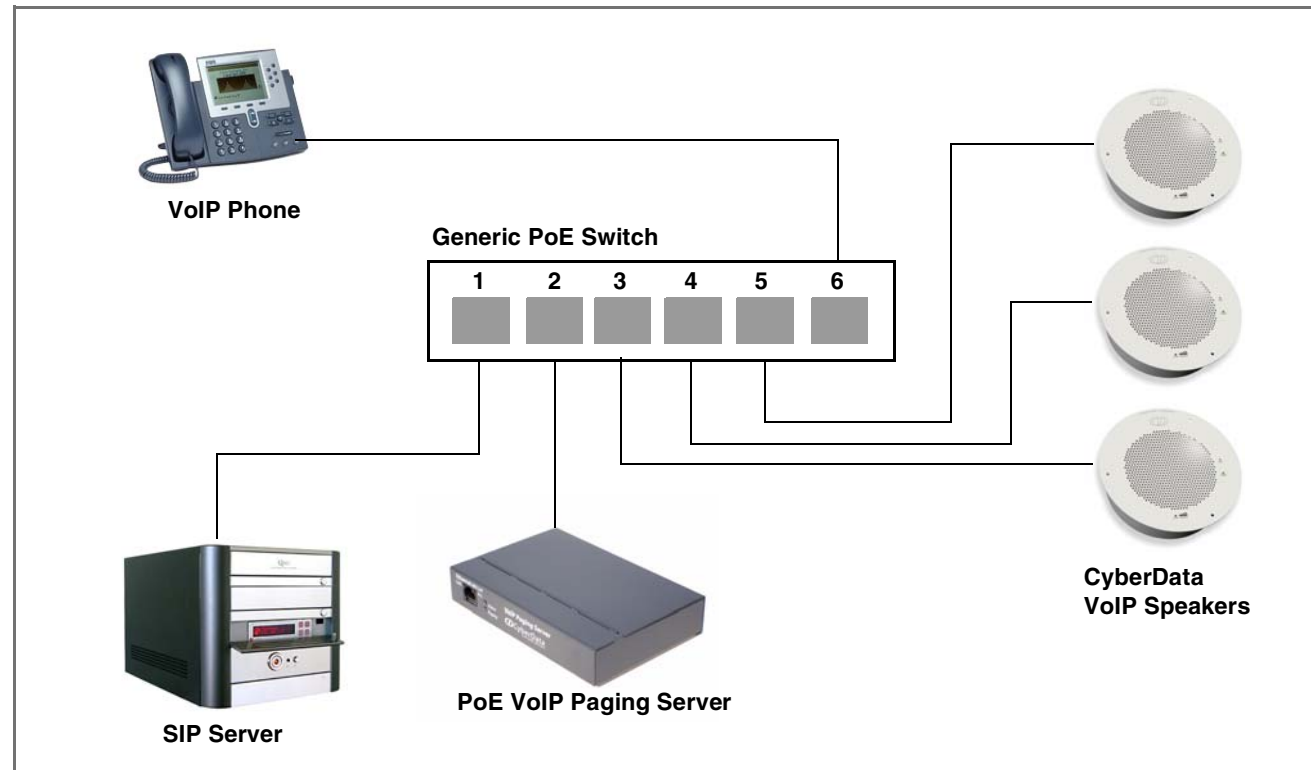

Setting Up the PoE VoIP Paging Server

| | |
|--|---|
| <p>PoE</p> | <p>To set up the Paging Server, connect the device to your network:</p> <p>Poe</p> <ul style="list-style-type: none"> For PoE, plug one end of an 802.3af Ethernet cable into the Paging Server Ethernet port. Plug the other end of the Ethernet cable into your network. See the figure on the left. |
| <p>Non PoE (with 48 VDC power supply)</p> | <p>Non-Poe</p> <ul style="list-style-type: none"> For Non-PoE, connect the Paging Server to a 48VDC power supply. See the figure on the left. |
| <p>Chassis Ground</p> | <p>Chassis Ground</p> <ul style="list-style-type: none"> If required, connect the earth grounding wire to the Chassis Ground. See the figure on the left. |

Verifying Operations and Settings

| | |
|---|--|
| <p>Front View with LEDs</p> <ul style="list-style-type: none"> Green Link light indicates network connectivity Orange Link light indicates 100 Mbps baud rate Yellow Link light indicates 10 Mbps baud rate Blinking yellow Activity light indicates network activity Blinking pale blue Status light indicates the unit is running Dark blue Paging light indicates the unit is paging | |
| <p>Back View with RTFM Switch</p> <p>To restore these parameters to the factory default settings:</p> <ol style="list-style-type: none"> Press and hold the RTFM switch for at least 20 seconds. Release the switch. The Status and the Paging LEDs will go off. The Link and Activity LEDs will come on for one second and go off to indicate that the reset process is starting. During the reset process, the Link LED will come on and the Activity LED will blink. After five seconds, the Status and Paging LEDs come back on. The Paging Server settings are restored to the factory defaults. | |