



VoIP Speaker Ceiling Tile Reinforcement Mount

010991

Features

- Easy tile ceiling installation
- Mounting kit included
- Electrogalvanized steel construction
- RoHS compliant
- Two years warranty

Product Components List

- (1) Mount, ceiling tile reinforcement

Dimensions

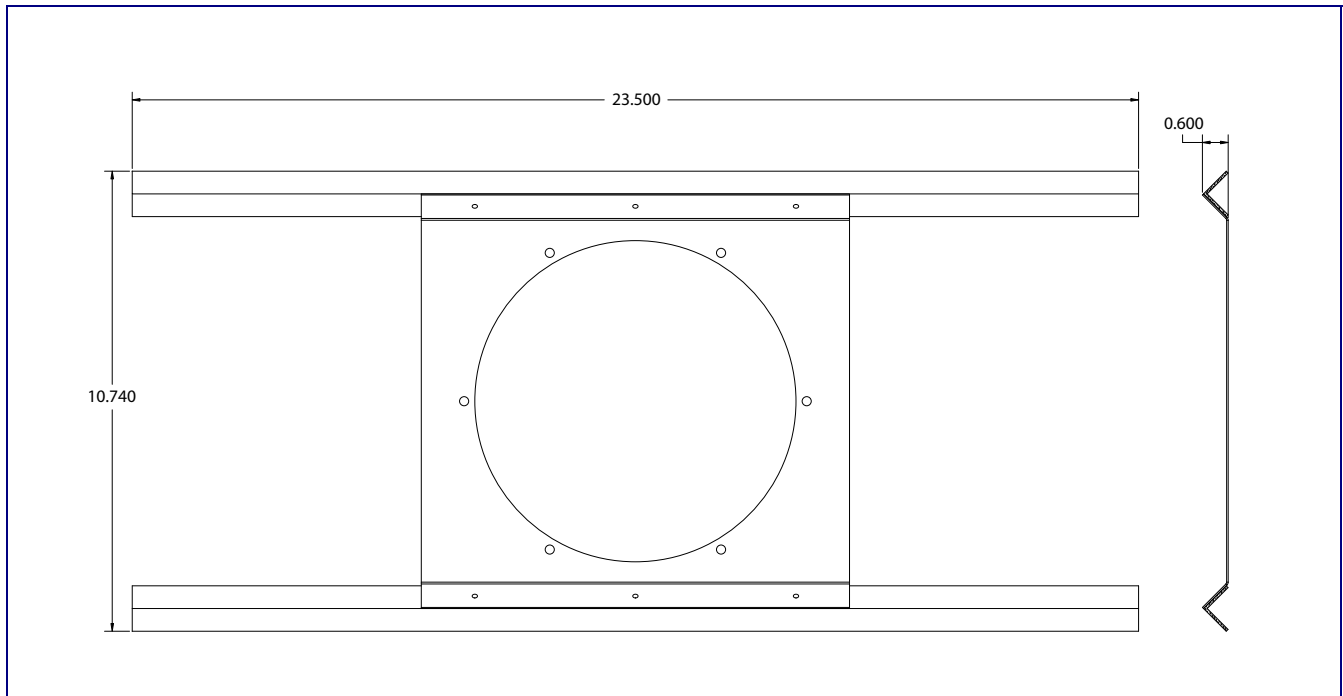

Exploded View

