



4-Port Powered USB 2.0 Hub Operations Guide

with External Power Supply

Part #010807

CyberData Corporation
3 Justin Court
Monterey, CA 93940
(831) 373-2601

4-Port PoweredUSB 2.0 Hub Operations Guide 930103G Part # 010807

COPYRIGHT NOTICE:

© 2011, CyberData Corporation, ALL RIGHTS RESERVED.

This manual and related materials are the copyrighted property of CyberData Corporation. No part of this manual or related materials may be reproduced or transmitted, in any form or by any means (except for internal use by licensed customers), without prior express written permission of CyberData Corporation. This manual, and the products, software, firmware, and/or hardware described in this manual are the property of CyberData Corporation, provided under the terms of an agreement between CyberData Corporation and recipient of this manual, and their use is subject to that agreement and its terms.

DISCLAIMER: Except as expressly and specifically stated in a written agreement executed by CyberData Corporation, CyberData Corporation makes no representation or warranty, express or implied, including any warranty or merchantability or fitness for any purpose, with respect to this manual or the products, software, firmware, and/or hardware described herein, and CyberData Corporation assumes no liability for damages or claims resulting from any use of this manual or such products, software, firmware, and/or hardware. CyberData Corporation reserves the right to make changes, without notice, to this manual and to any such product, software, firmware, and/or hardware.

OPEN SOURCE STATEMENT: Certain software components included in CyberData products are subject to the GNU General Public License (GPL) and Lesser GNU General Public License (LGPL) "open source" or "free software" licenses. Some of this Open Source Software may be owned by third parties. Open Source Software is not subject to the terms and conditions of the CyberData COPYRIGHT NOTICE or software licenses. Your right to copy, modify, and distribute any Open Source Software is determined by the terms of the GPL, LGPL, or third party, according to who licenses that software.

Software or firmware developed by CyberData that is unrelated to Open Source Software is copyrighted by CyberData, subject to the terms of CyberData licenses, and may not be copied, modified, reverse-engineered, or otherwise altered without explicit written permission from CyberData Corporation.

TRADEMARK NOTICE: CyberData Corporation and the CyberData Corporation logos are trademarks of CyberData Corporation. Other product names, trademarks, and service marks may be the trademarks or registered trademarks of their respective owners.

CyberData

The IP Endpoint Company

Technical Support

The fastest way to get technical support for your VoIP product is to submit a VoIP Technical Support form at the following website:
<http://www.cyberdata.net/support/contactsupportvoip.html>

We have several technical support staff monitoring this form and they will contact you within 12 hours after receiving a submission.

Phone: (831) 373-2601, Ext. 333

Email: support@cyberdata.net

Fax: (831) 373-4193

Company and product information is at www.cyberdata.net.



Revision Information

Revision 930103G, which was released on August 31, 2011, has the following changes:



- Updates [Section Appendix C: "Troubleshooting/Technical Support"](#).

Important Safety Instructions

1. Read these instructions.
2. Keep these instructions.
3. Heed all warnings.
4. Follow all instructions.
5. Do not use this apparatus near water.
6. Clean only with dry cloth.
7. Do not block any ventilation openings. Install in accordance with the manufacturer's instructions.
8. Do not install near any heat sources such as radiators, heat registers, stoves, or other apparatus (including amplifiers) that produce heat.
9. Do not defeat the safety purpose of the polarized or grounding-type plug. A polarized plug has two blades with one wider than the other. A grounding type plug has two blades and a third grounding prong. The wide blade or the third prong are provided for your safety. If the provided plug does not fit into your outlet, consult an electrician for replacement of the obsolete outlet.
10. Protect the power cord from being walked on or pinched particularly at plugs, convenience receptacles, and the point where they exit from the apparatus.
11. Only use attachments/accessories specified by the manufacturer.
12. Refer all servicing to qualified service personnel. Servicing is required when the apparatus has been damaged in any way, such as power-supply cord or plug is damaged, liquid has been spilled or objects have fallen into the apparatus, the apparatus has been exposed to rain or moisture, does not operate normally, or has been dropped.
13. Prior to installation, consult local building and electrical code requirements.

 <p>GENERAL ALERT</p>	<p>Warning <i>Electrical Hazard:</i> This product should be installed by a licensed electrician according to all local electrical and building codes.</p>
 <p>GENERAL ALERT</p>	<p>Warning <i>Electrical Hazard:</i> To prevent injury, this apparatus must be securely attached to the floor/wall in accordance with the installation instructions.</p>

Pictorial Alert Icons

	<p>General Alert <i>This pictorial alert indicates a potentially hazardous situation. This alert will be followed by a hazard level heading and more specific information about the hazard.</i></p>
	<p>Ground <i>This pictorial alert indicates the Earth grounding connection point.</i></p>

Hazard Levels

Danger: Indicates an imminently hazardous situation which, if not avoided, will result in death or serious injury. This is limited to the most extreme situations.

Warning: Indicates a potentially hazardous situation which, if not avoided, could result in death or serious injury.

Caution: Indicates a potentially hazardous situation which, if not avoided, could result in minor or moderate injury. It may also alert users against unsafe practices.

Notice: Indicates a statement of company policy (that is, a safety policy or protection of property).

The safety guidelines for the equipment in this manual do not purport to address all the safety issues of the equipment. It is the responsibility of the user to establish appropriate safety, ergonomic, and health practices and determine the applicability of regulatory limitations prior to use. Potential safety hazards are identified in this manual through the use of words *Danger*, *Warning*, and *Caution*, the specific hazard type, and pictorial alert icons.

Contents

Chapter 1 Product Overview	1
1.1 Product features	1
1.2 License note	2
1.3 Documentation note	2
1.4 Dimensions	3
Chapter 2 Installing and Using the 4-Port PoweredUSB Hub	4
2.1 Product Components List	5
2.2 Product Compatibility	6
2.3 Installation	6
2.4 Connections	7
2.4.1 Power Supply	7
2.4.2 Host Connector	8
2.4.3 PoweredUSB Connections	8
2.4.4 Connector Color Keys	9
2.4.5 Peripherals Connections to the 4-Port PoweredUSB Hub	10
2.4.6 Peripheral Cable Connection Options	11
2.5 Operation	14
2.5.1 POS Peripheral Caveat	14
2.6 Port Electrical Specifications	15
2.6.1 Standard USB lower A supply	15
2.6.2 PoweredUSB supply	15
Appendix A Regulatory and Safety Information	16
Appendix B Setting up the Hub on Windows XP	17
Appendix C Troubleshooting/Technical Support	18
C.1 Frequently Asked Questions (FAQ)	18
C.2 Documentation	18
C.3 Contact Information	19
C.4 Warranty	20
C.4.1 Warranty & RMA Returns within the United States	20
C.4.2 Warranty & RMA Returns Outside of the United States	20
C.4.3 Spare in the Air Policy	20
C.4.4 Return and Restocking Policy	21
C.4.5 Warranty and RMA Returns Page	21
Index	22

1 Product Overview

The 4-Port PoweredUSB Hub provides a simple, affordable way to add up to four PoweredUSB ports to your PC. These additional ports are controlled by the PC's Standby and Wake commands. This add-on Hub makes it easy to connect the PC to devices that require more than the 500mA of +5 volts supplied with the standard USB interface.

Figure 1-1. CyberData 4-Port PoweredUSB 2.0 Hub



1.1 Product features

- 4 PoweredUSB ports
- One +24 volt up to 2.3A
- Three +12 volt up to 1.5A each
- Short circuit and over current protected
- Multiple power supply options
- Plug-n-Play installation
- Peripheral power controlled by PC stand-by and wake commands
- LED indicators for port power output and USB 2.0 status
- Two-year warranty

1.2 License note

The PoweredUSB controller board contains certain technology that is covered by an IBM® patent. CyberData Corporation is licensed with IBM to manufacture, and to sell or lease products that incorporate this technology. This license also permits other entities to resell or release these Cyberdata products after they have been purchased from CyberData.

1.3 Documentation note

The documentation for this product is released in an English language version only.

1.4 Dimensions

Figure 1-2. Dimensions

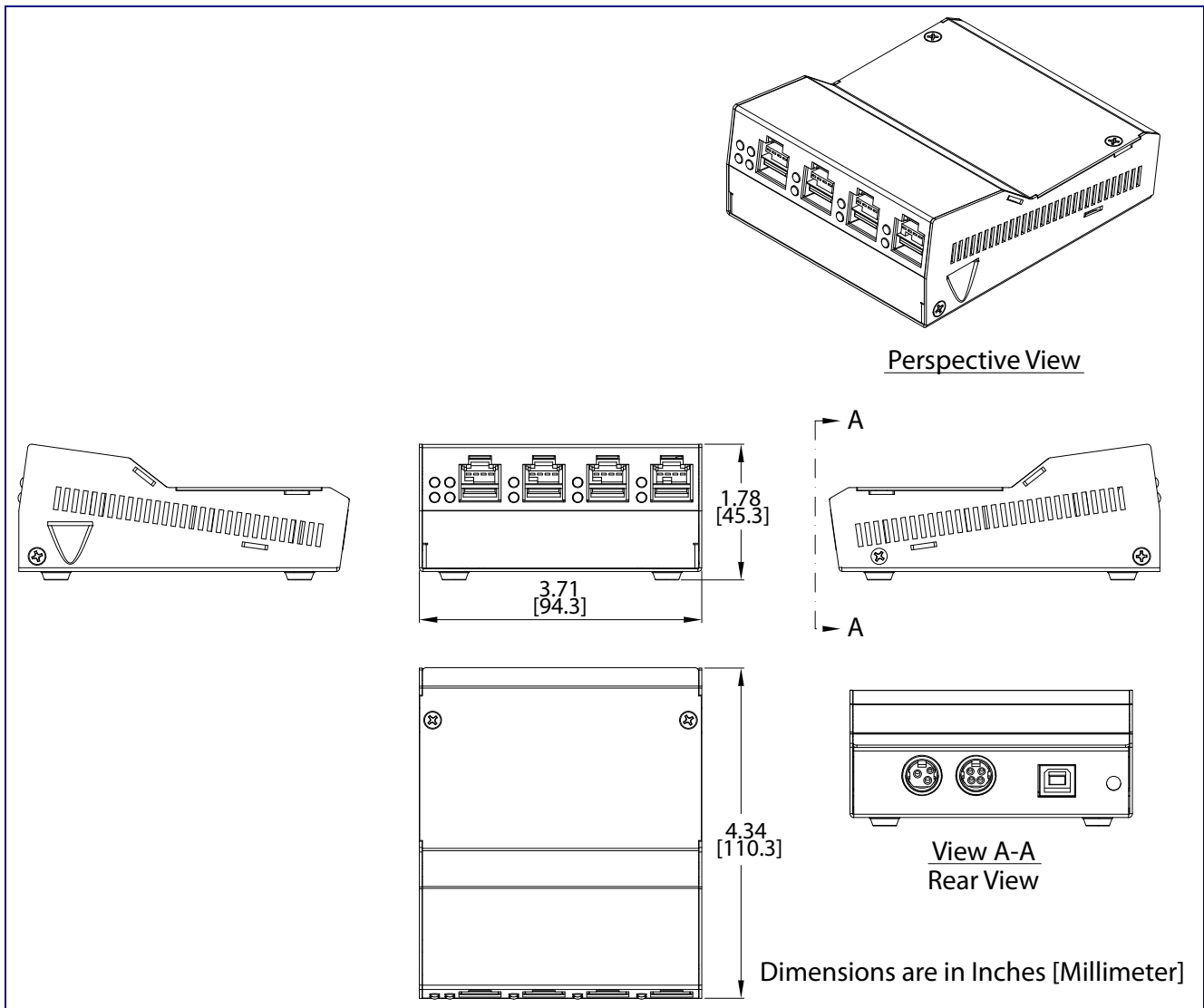

2 Installing and Using the 4-Port PoweredUSB Hub

This chapter provides the instructions, illustrations, and background information you need to install, and begin working with the 4-Port PoweredUSB Hub.

- [Section 2.1, "Product Components List"](#)
- [Section 2.2, "Product Compatibility"](#)
- [Section 2.3, "Installation"](#)
- [Section 2.4, "Connections"](#)
- [Section 2.5, "Operation"](#)
- [Section 2.6, "Port Electrical Specifications"](#)

Figure 2-3. CyberData 4-Port PoweredUSB 2.0 Hub



2.1 Product Components List

The 4-Port PoweredUSB 2.0 Hub package includes these parts:

- (1) 4-Port PoweredUSB Hub
- Power Supply, 24VDC, Desk-top, 4-Pin Hosiden style plug
- (1) Accessory Kit
 - (1) Short USB 2.0 Hi-Speed host cable
 - (1) Host USB cable strain relief clamp
 - (1) *4-Port PoweredUSB 2.0 Hub Operations Guide*

Figure 2-4. CyberData 4-Port PoweredUSB 2.0 Hub—Front View

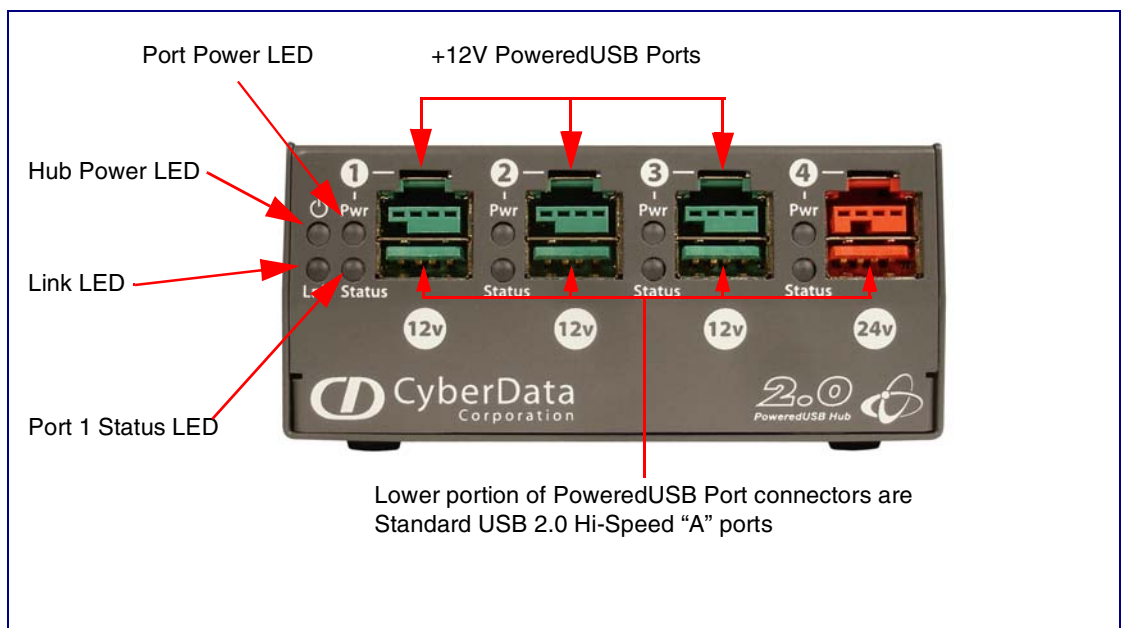

Figure 2-5. CyberData 4-Port PoweredUSB 2.0 Hub—Back View



2.2 Product Compatibility

The 4-Port PoweredUSB Hub is compatible with the following operating systems and USB standards.

Table 2-1. Operating Systems

Operating systems	USB
Windows 2000 and XP	2.0 Standard
LINUX	PoweredUSB 0.8g
Mac OS-X	

2.3 Installation

The 4-Port PoweredUSB Hub is a tabletop unit with mounting feet that sit on a flat surface.

2.4 Connections

The following topics provide illustrations and information on connecting the 4-Port PoweredUSB Hub to power supplies, the host, and peripheral devices.

- [Section 2.4.1, "Power Supply"](#)
- [Section 2.4.2, "Host Connector"](#)
- [Section 2.4.3, "PoweredUSB Connections"](#)
- [Section 2.4.4, "Connector Color Keys"](#)
- [Section 2.4.5, "Peripherals Connections to the 4-Port PoweredUSB Hub"](#)
- [Section 2.4.6, "Peripheral Cable Connection Options"](#)

2.4.1 Power Supply

The PoweredUSB specification requires supplying +24V at 2.3A and +12V at 1.5A to each voltage designated port. These requirements are met only if the power supply has sufficient wattage for this amount of power.

The Epson PS180 brick and Dell printer power supply are examples of lower-cost alternate power supplies that can be used with this Hub and peripherals requiring less power. Two power plug receptacles are provided on the back of the 4-Port PoweredUSB Hub to facilitate the use of alternate power supplies.

The three-pin connector is normally used for the Dell and Epson Bricks. The four-pin connector is used for a high-current power supply. See [Figure 2-10](#) for an illustration of cable routing from the 4-Port PoweredUSB Hub.

CAUTION The P1 and P2 DC input jacks on the back of this Hub are for *input only*. Do not plug power supplies into both input jacks simultaneously as equipment damage that might void the product warranty could occur.

Figure 2-6. Power Connectors—Back View

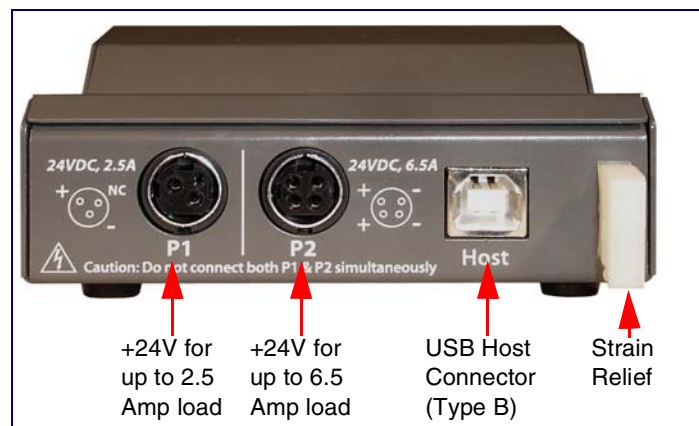

2.4.2 Host Connector

The connection to the host computer is achieved via a standard USB 2.0 certified Hi-Speed “A” to “B” cable that is included in the Accessory Kit, or with any equivalent USB 2.0 certified Hi-Speed cable. Refer to the [Section 2.1, "Product Components List"](#) for information about the Accessory Kit.

Figure 2-7. Host connector with strain relief

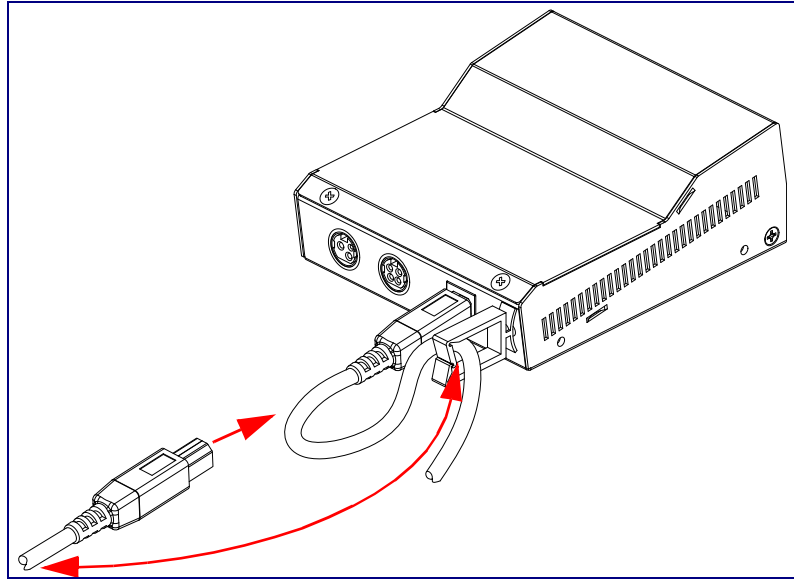

2.4.3 PoweredUSB Connections

The PoweredUSB connections are standard USB “A” connectors with four extra pins to supply higher voltages. See [Figure 2-9](#) for an illustration. The lower portion of the “A” connector side on this product can be used alone, without the locking PoweredUSB connector.

2.4.4 Connector Color Keys

The PoweredUSB connectors are color keyed so that *only* the correct voltage cables can be installed.

Figure 2-8. Color-Coding for Connectors

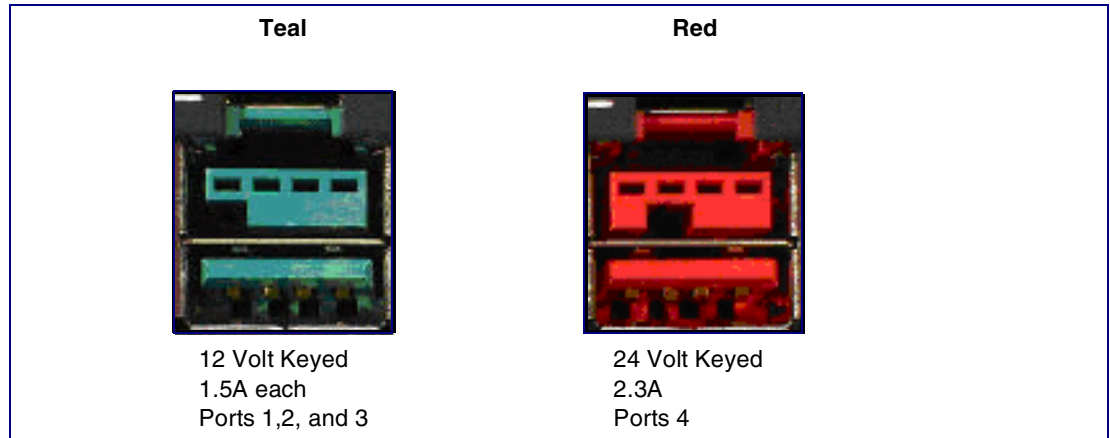
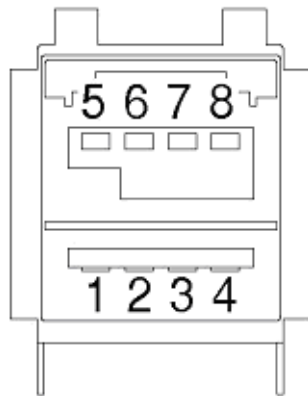

Figure 2-9. USB PoweredUSB Socket Connector Pin Assignments



PIN OUT		
Pin	Signal Description	
1	Vbus	USB standard "A"
2	D-	USB standard "A"
3	D+	USB standard "A"
4	Ground	USB standard "A"
5	Ground	USB PlusPower
6	Vplus	USB PlusPower
7	Vplus	USB PlusPower
8	Ground	USB PlusPower
Shell	Shield	

2.4.5 Peripherals Connections to the 4-Port PoweredUSB Hub

This figure illustrates the cable routing from the 4-Port PoweredUSB Hub to the Dell Retail Integrator.

Figure 2-10. Top view of Hub PoweredUSB cable routing

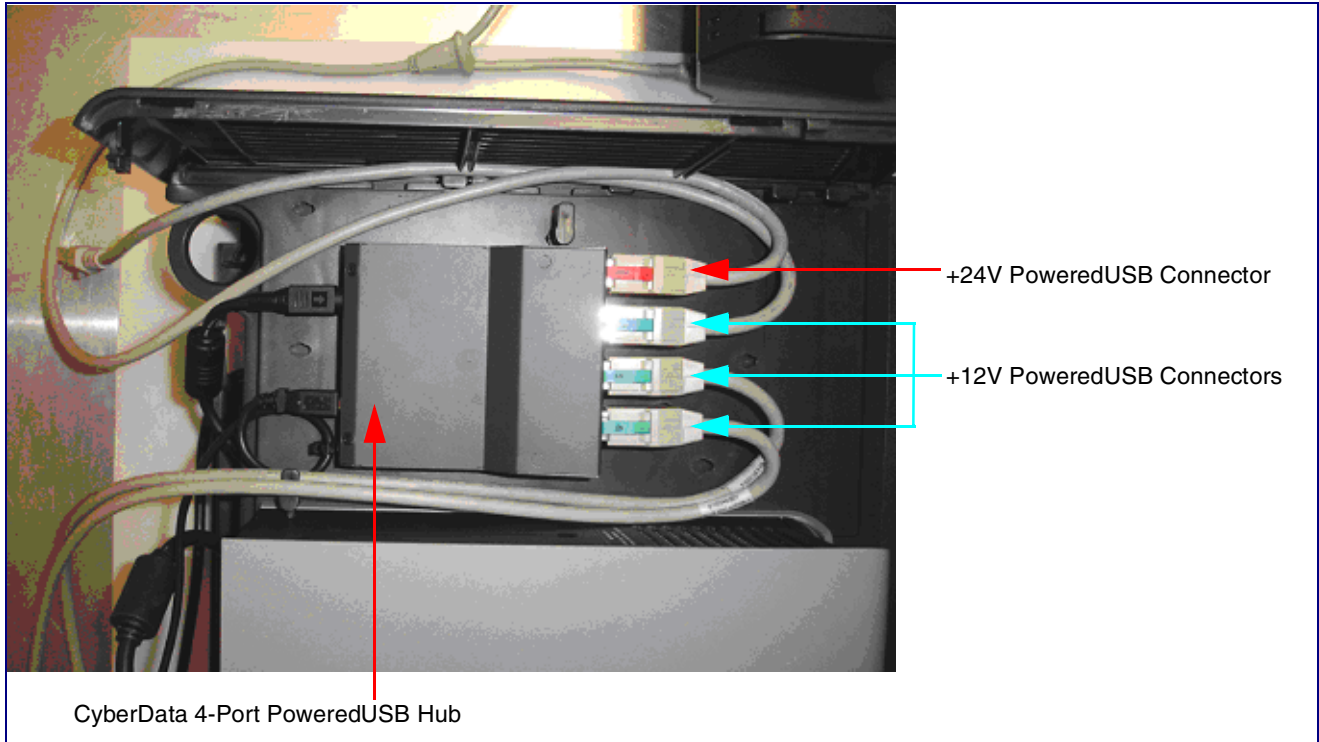

2.4.6 Peripheral Cable Connection Options

Figures 10 through 16 provide examples of peripheral cable combinations and connection options for the 4-Port PoweredUSB Hub. The following table provides details about the CyberData PoweredUSB Cables displayed in these figures.

PoweredUSB cable Custom cables of different lengths and colors can be purchased from CyberData as follows:
sources

- Via email: sales@cyberdata.net
- Via phone: Sales (831) 373-2601 Extension 334

Table 3. CyberData PoweredUSB Cables

Figure	PoweredUSB Cable Description	CyberData Part Number
Figure 2-11	12V to 2x4	010693C
Figure 2-12	12V to 12V Power Jack	Contact CyberData
Figure 2-13	24V PoweredUSB to 3-Pin Power Mini-DIN	010631A
Figure 2-14	24V to "Y" Cable 3-Pin Power Mini-DIN to USB "B"	010714A
Figure 2-15	12V to "Y" Cable, RS232 and Power Jack	010763
Figure 2-16	24V to 1x8	010617A
Figure 2-17	24V to "Y" Cable, RS232 and Power Jack	

Figure 2-11. Cable, +12V PoweredUSB to 2x4 PoweredUSB

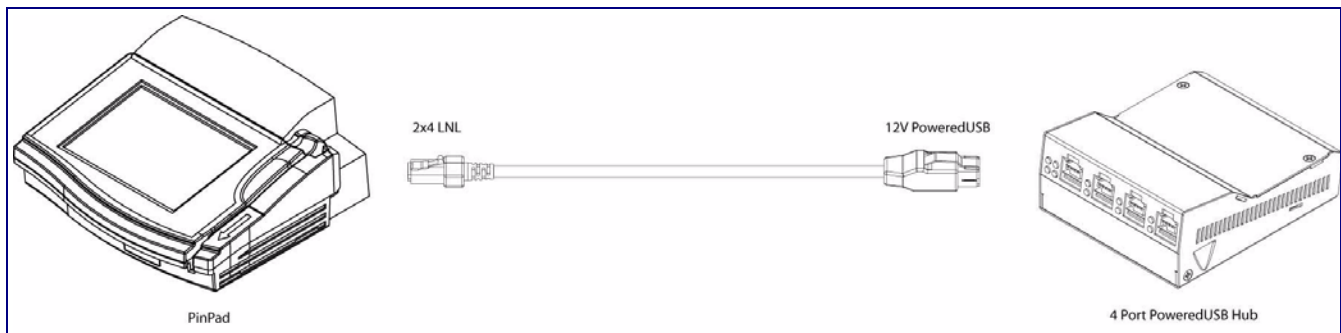

Figure 2-12. Cables; +12V PoweredUSB to +12V Power Jack and RS-232 to RS-232

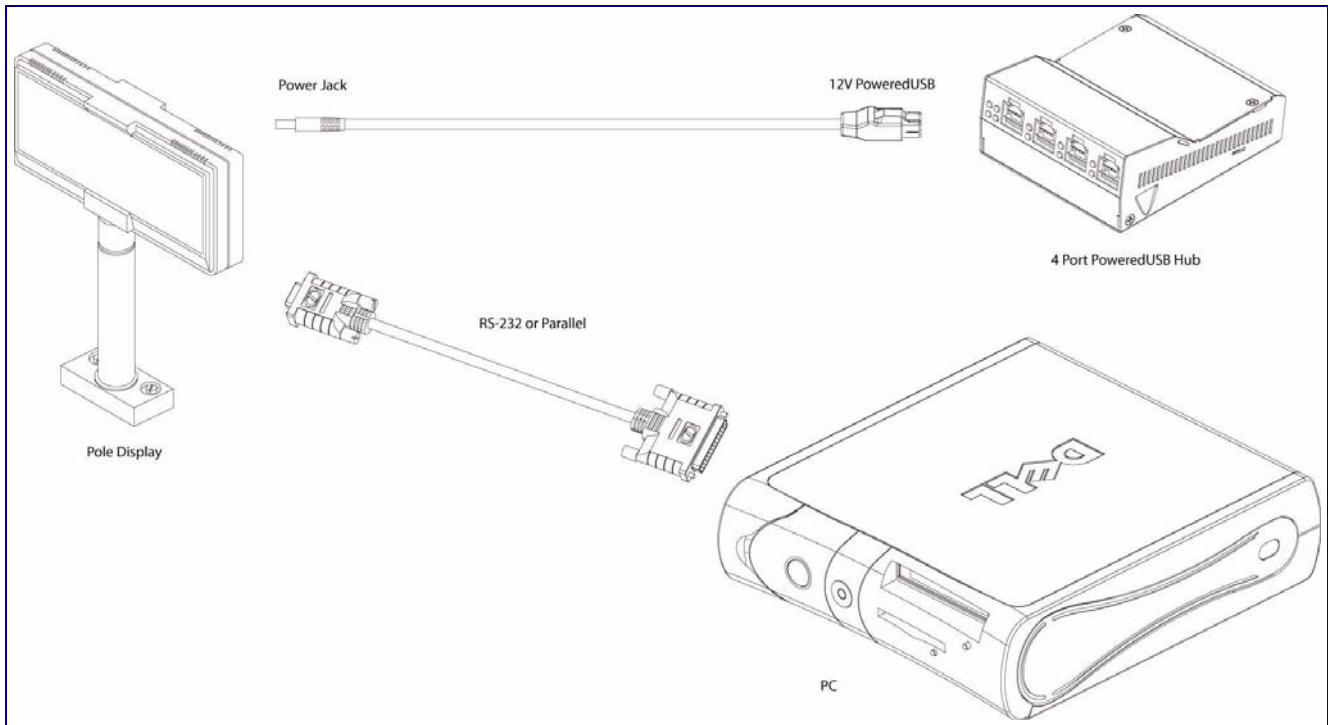

Figure 2-13. Cables; +24V PoweredUSB to 3-Pin Mini-DIN and RS-232 to RS-232 or Parallel to Parallel

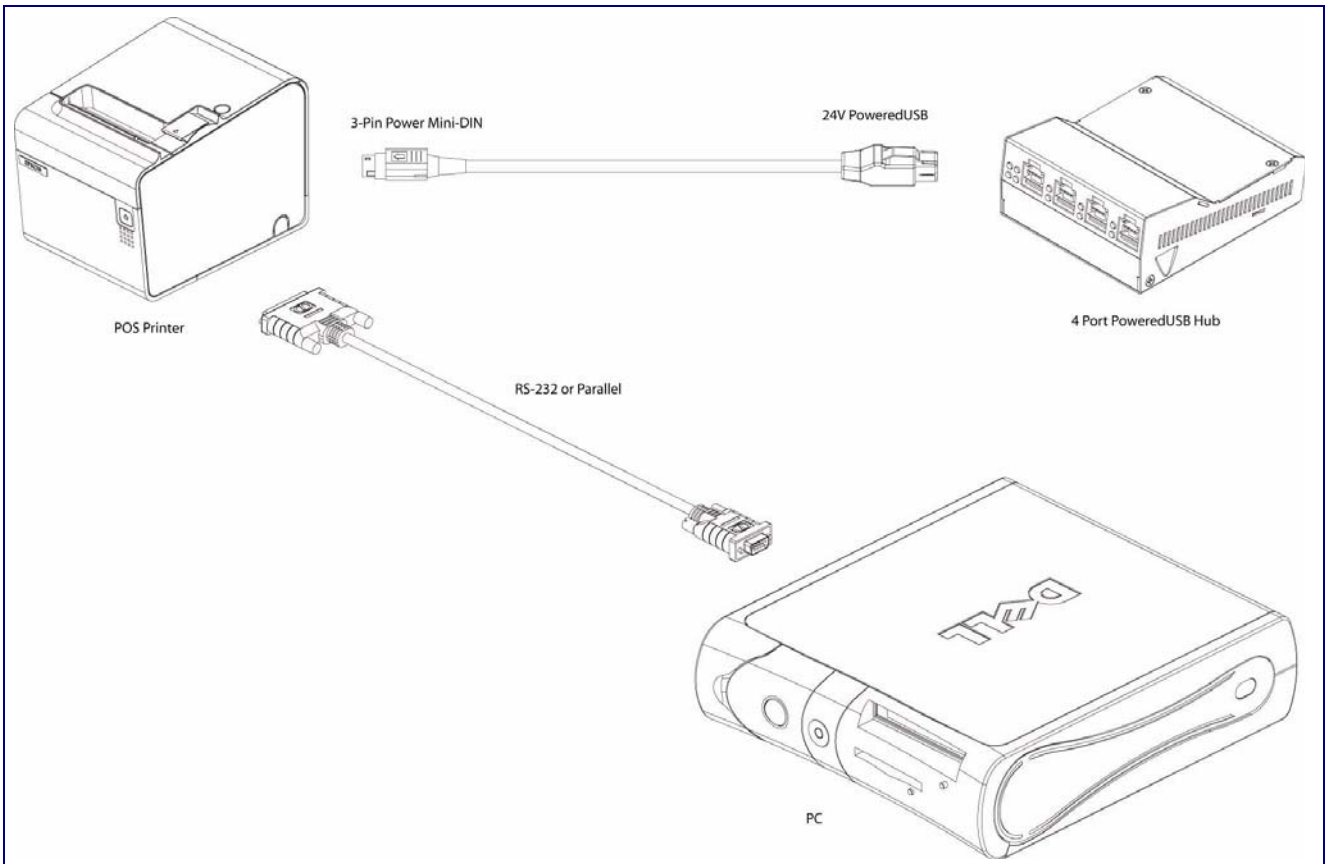

Figure 2-14. “Y” Cable, +24V PoweredUSB to 3-Pin Power Mini-DIN and USB “B” Connectors

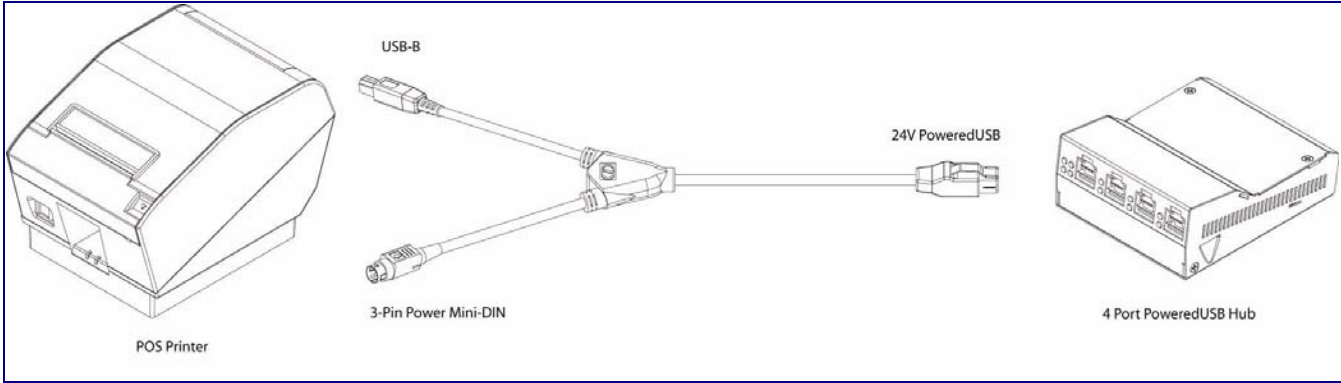

Figure 2-15. RS232 to USB Converter “Y” Cable +12V (PC Enumerates this device as an RS-232 COM port)

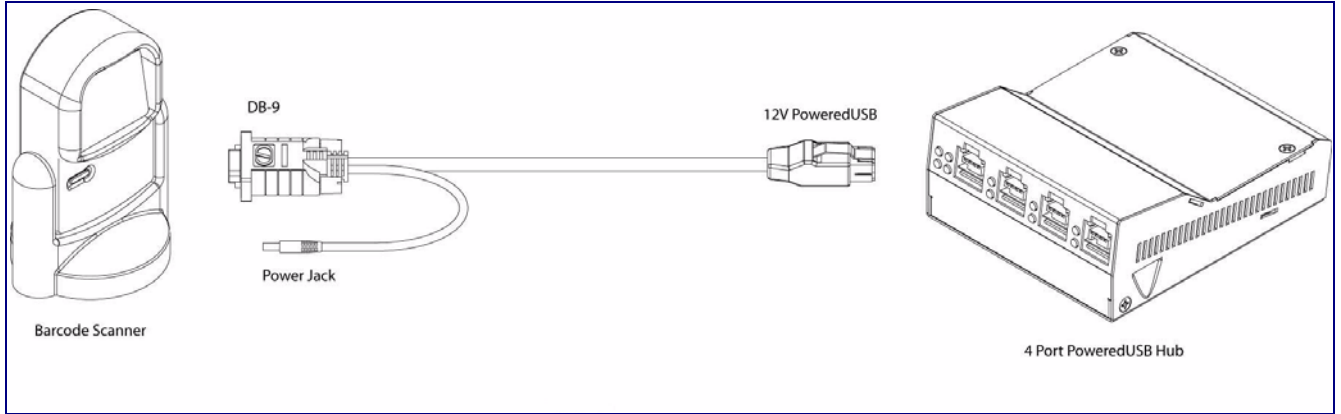
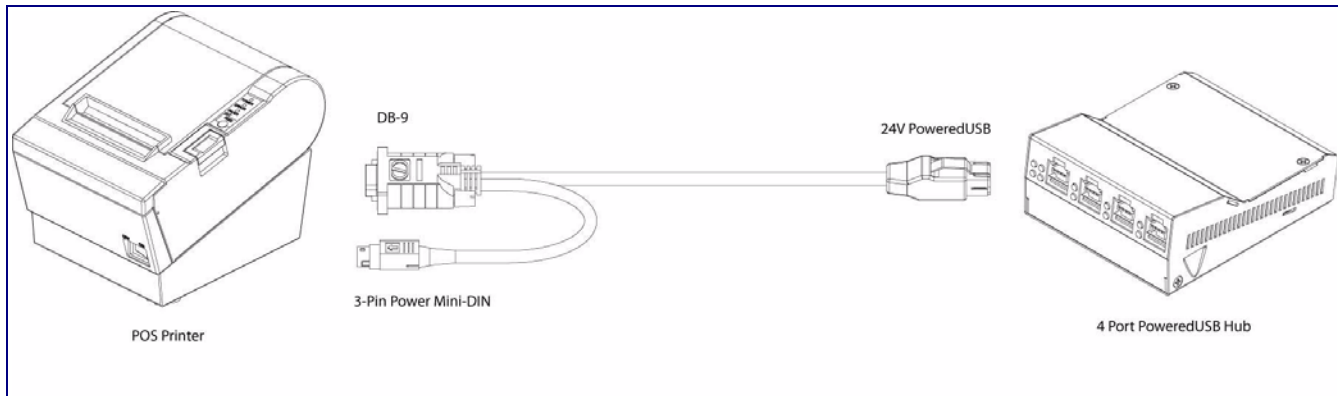

Figure 2-16. Cable, +24V PoweredUSB to 1x8 PoweredUSB



Figure 2-17. RS232 to USB Converter “Y” Cable +24V

2.5 Operation

The 4-Port PoweredUSB Hub is a standard USB Hub that complies with the USB 2.0 specification, and adds PoweredUSB ports. When connected to a Host, it is enumerated as a *Generic USB Hub*. This Hub also meets the PoweredUSB .08g specification. For more information about this specification, go to www.poweredusb.org.

2.5.1 POS Peripheral Caveat

According to the USB 2.0 specification, devices attached to a USB interface should enumerate from the Hub's USB Vbus, regardless of the PoweredUSB powered ports. Some POS devices do not comply with this specification, and will not enumerate unless the upper sections of the PoweredUSB ports are active.

When running on operating systems such as Windows XP with *no* devices attached (an empty Hub), the operating system turns the Hub off. The operating system does not detect non-compliant peripherals when they are hot-plugged into an empty Hub. Consequently PoweredUSB power is not supplied to the peripheral. In this case, you can restore correct operation as follows.

1. Unplug the Host side connection for five seconds, and then plug it in again.
2. Be sure that at least one USB device is plugged in when the computer is booted, or leaves standby mode.
3. Plug in a standard USB compliant device, such as a mouse or keyboard.
4. Disable the low-power, standby operation. With this configuration, power is always supplied to the PoweredUSB ports regardless of the PC's operational state. For more information, contact CyberData as instructed in [Appendix C, "Troubleshooting/Technical Support"](#).

2.6 Port Electrical Specifications

The 4-Port PoweredUSB Hub adheres to the USB 2.0 electrical specifications as follows:

2.6.1 Standard USB lower A supply

Each lower portion of the PoweredUSB port provides +5V @ 500mA. If more than 500mA are drawn from a port, that port goes into USB over current, the +5 volts is turned off, and the condition is reported to the host according to USB 2.0 specifications.

2.6.2 PoweredUSB supply

The listed maximum currents depend on the selected power supply. Both the +12V and +24V PoweredUSB ports are protected with active over current circuits. If an over current condition occurs, unplug the DC connection, remove the overcurrent condition, and re-cycle the DC connection to the Hub by unplugging it, and then plugging it in again.

- +12V Ports (3) – 1.5A each
- +24V Port (1) – 2.3A

Appendix A: Regulatory and Safety Information

Regulatory standards	<p>FCC Statement: This equipment has been tested and found to comply with the limits for a Class A digital device, pursuant to Part 15 of the FCC Rules. These limits are designed to provide reasonable protection against harmful interference when the equipment is operated in a commercial environment. This equipment generates, uses, and can radiate radio frequency energy and, if not installed and used in accordance with the instruction manual, may cause harmful interference to radio communications. Operation of this equipment in a residential area is likely to cause harmful interference in which case the user will be required to correct the interference at his own expense.</p>
Safety standards	<ul style="list-style-type: none"> ● UL60950-1; Information Technology Equipment ● CSA C22.2 No. 60950-01, Information Technology Equipment ● EN60950-1, Information Technology Equipment ● IEC60950-1, Information Technology Equipment
EMC	<p>For the USA and Canada, this device complies with:</p> <ul style="list-style-type: none"> ● Title 47 of the CFR, Part 15, Subpart B, Section 15.107(b) ● Title 47 of the CFR, Part 15, Subpart B, Section 15.109 (b) ● ICES-003
CE Declaration of Conformity	<p>This device complies with:</p> <ul style="list-style-type: none"> ● Directive 89/336/EEC ● EN55022 Class A 1998 <ul style="list-style-type: none"> • EN61000-3-2: 2000 • EN61000-3-3: 1995 ● EN55024: 1998 <ul style="list-style-type: none"> • EN61000-4-2: 1995 • EN 61000-4-3:1996 • EN 61000-4-4: 1995 • EN 61000-4-5: 1995 • EN 61000-4-6: 1996 • EN 61000-4-8: 1993 • EN 61000-4-11: 1995

Appendix B: Setting up the Hub on Windows XP

For connecting the 4-Port PoweredUSB Hub to a PC running the Windows XP operating system, keep in mind:

1. Microsoft XP Service Pack 1 or higher must be installed.
2. When connecting the Hub for the first time, it is important to perform the enumeration correctly. A Microsoft XP Service Pack issue does not enumerate and recognize a Hub when no devices are attached to it. To correctly enumerate the 4-Port PoweredUSB Hub, attach a peripheral whose drivers are included in Windows XP, such as a USB mouse, prior to enumerating the Hub. To accomplish this:
 - a. Connect a USB mouse to one of the lower, standard USB, Hub ports.
 - b. Connect the power cord to the Hub.
 - c. With the PC powered up, connect the host control cable from the Hub to a USB port on the PC. Doing so displays the *Found new hardware* dialog, indicating that the PC is searching for drivers for the Hub.
 - d. When the PC completes the driver search, it displays the *Found new hardware* dialog, in search of a driver for the mouse. If required, click **Next** in all screens of the wizard to complete the driver selection for the mouse.

At this point, you should be able to plug in and install a USB device provided you have also installed its drivers, or have them available for installation.

Appendix C: Troubleshooting/Technical Support

C.1 Frequently Asked Questions (FAQ)

To see a list of frequently asked questions for your product, go to the following website:

<http://www.cyberdata.net/products/retail/pusb/pusb4porthub/faqs.html>

C.2 Documentation

The documentation for this product is released in an English language version only. You can download PDF copies of CyberData product documentation by going to the following website:

<http://www.cyberdata.net/products/retail/pusb/pusb4porthub/docs.html>

C.3 Contact Information

Contact	<p>CyberData Corporation 3 Justin Court Monterey, CA 93940 USA www.CyberData.net Phone: 800-CYBERDATA (800-292-3732) Fax: 831-373-4193</p>
Sales	<p>Sales 831-373-2601 Extension 334</p>
Technical Support	<p>The fastest way to get technical support for your VoIP product is to submit a VoIP Technical Support form at the following website:</p> <p>http://www.cyberdata.net/support/contactsupportvoip.html</p> <p>We have several technical support staff monitoring this form and they will contact you within 12 hours after receiving a form submission.</p> <p>Phone: (831) 373-2601, Ext. 333 Email: support@cyberdata.net</p>
Returned Materials Authorization	<p>To return the product, contact the Returned Materials Authorization (RMA) department:</p> <p>Phone: 831-373-2601, Extension 136 Email: RMA@CyberData.net</p> <p>When returning a product to CyberData, an approved CyberData RMA number must be printed on the outside of the original shipping package. No product will be accepted for return without an approved RMA number. Send the product, in its original package, to the following address:</p> <p>CyberData Corporation 3 Justin Court Monterey, CA 93940 Attention: RMA "your RMA number"</p>
RMA Status Form	<p>If you need to inquire about the repair status of your product(s), please use the CyberData RMA Status form at the following web address:</p> <p>http://www.cyberdata.net/support/rmastatus.html</p>

C.4 Warranty

CyberData warrants its product against defects in material or workmanship for a period of two years from the date of purchase. Should the product fail within the warranty period, CyberData will repair or replace the product free of charge. This warranty includes all parts and labor.

Should the product fail out-of-warranty, a flat rate repair charge of one half of the purchase price of the product will be assessed. Repairs that are in warranty but are damaged by improper modifications or abuse, will be charged at the out-of-warranty rate. Products shipped to CyberData, both in and out-of-warranty, are shipped at the expense of the customer. Shipping charges for repaired products shipped back to the customer by CyberData, will be paid by CyberData.

CyberData shall not under any circumstances be liable to any person for any special, incidental, indirect or consequential damages, including without limitation, damages resulting from use or malfunction of the products, loss of profits or revenues or costs of replacement goods, even if CyberData is informed in advance of the possibility of such damages.

C.4.1 Warranty & RMA Returns within the United States

If service is required, you must contact CyberData Technical Support prior to returning any products to CyberData. Our Technical Support staff will determine if your product should be returned to us for further inspection. If Technical Support determines that your product needs to be returned to CyberData, an RMA number will be issued to you at this point.

Your issued RMA number must be printed on the outside of the shipping box. No product will be accepted for return without an approved RMA number. The product in its original package should be sent to the following address:

CyberData Corporation
3 Justin Court.
Monterey, CA 93940
Attn: RMA "xxxxxx"

C.4.2 Warranty & RMA Returns Outside of the United States

If you purchased your equipment through an authorized international distributor or reseller, please contact them directly for product repairs.

C.4.3 Spare in the Air Policy

CyberData now offers a *Spare in the Air* no wait policy for warranty returns within the United States and Canada. More information about the *Spare in the Air* policy is available at the following web address:

<http://www.cyberdata.net/support/warranty/spareintheair.html>

C.4.4 Return and Restocking Policy

For our authorized distributors and resellers, please refer to your CyberData Service Agreement for information on our return guidelines and procedures.

For End Users, please contact the company that you purchased your equipment from for their return policy.

C.4.5 Warranty and RMA Returns Page

The most recent warranty and RMA information is available at the CyberData Warranty and RMA Returns Page at the following web address:

<http://www.cyberdata.net/support/warranty/index.html>

Index

A

accessory kit 5, 8
active over current circuits. 15

C

cable routing 10
cable strain relief clamp 5
cables for connecting peripherals 11
CE conformity 16
CFR 16
color keys for ports 9
compatibility matrix 6
components list 5
connector color keys 9
contact information 19
contact information for CyberData 19
CyberData
 license with IBM 2
CyberData contact information 19

D

DC input jacks 7
Dell printer power supply 7

E

EMC 16
enumeration 14, 17
Epson PS180 brick 7

F

FCC 16
features 1

G

generic USB hub 14

H

hazard levels v
high-current power supply 7
host connector 5, 8

I

IBM 2
ICES 16
Information Technology Equipment 16
installation 6

L

license 2

M

Microsoft XP Service Pack 1 17

O

over current protection 1

P

peripheral connections 11
power supply connections 7
PoweredUSB .08g specification 14
PoweredUSB connections 8
product
 accessory kit 5, 8
 CE conformity 16
 compatibility matrix 6
 components list 5
 enumerating 14
 enumeration 17
 features 1
 installation 6
 regulatory standards 16
 resell/release conditions 2

product compatibility 6

R

regulatory standards 16
return and restocking policy 21
RMA returned materials authorization 19
RMA status 19

S

safety instructions iv
sales 19
service 19
short circuit protection 1
Spare in the Air Policy 20

T

tech support 19
technical support, contact information 19

U

USB
2.0 specification 14
over current 15

W

warranty 1, 20
warranty & RMA returns outside of the United States 20
warranty & RMA returns within the United States 20
warranty and RMA returns page 21
warranty policy at CyberData 20
Windows XP 14, 17