

KS1000 Retail Hub

The CyberData KS1000 Retail Hub provides a simple and affordable POS migration strategy for Retailers. Availability of 8 powered serial ports allows for the legacy connectivity of existing peripherals while the availability of 8 PoweredUSB ports allows for future peripheral connectivity.

Requiring only a single, standard USB connection to the host PC, CyberData's KS1000 Retail Hub is the centerpiece of a POS migration strategy. This hub-based solution allows Retailers the ability to upgrade the host PC or peripherals as time and budgets permit or as new technologies become available.

The KS1000 Retail Hub also provides these additional Retail connectivity ports:

- PS2 port for keyboard or magnetic stripe reader
- Cash Drawer port with +24V power, trigger and status
- 24V, 3A receipt printer power connector
- RS232 with +5V and +12V support

Features

- 8 PoweredUSB ports
- 8 powered serial ports
- PS/2 port for keyboard and/or magnetic stripe reader
- Cash Drawer port with +24V power, trigger and status
- Internal power supply
- Optional internal USB drive
- External LED's to show port power and status
- Over current protection
- 2 AC pass through connections



Specifications

Part Number	010896
PoweredUSB Power Output* (Standard)	1 @ 24V 2.3A 7 @ 12V 1.5A each
PoweredUSB Ports	8
RS232 Ports	8 DB9M with power option
External LEDs	Power, link & status
Power Input	90 - 264AC, 50/60Hz
Regulatory Compliance	FCC Class B, UL 60950-1, CE
Dimensions	8.9 x 5.7 x 3.5" (W x D x H)
Warranty	3 year limited

*All ports support standard "A" type +5V USB connection.

Compatibility

IBM PC Windows 2000/XP & WePOS compatible
Apple Computer & Linux also supported
USB Standard 2.0 is fully supported

KS1000 Retail Hub

Typical Installation

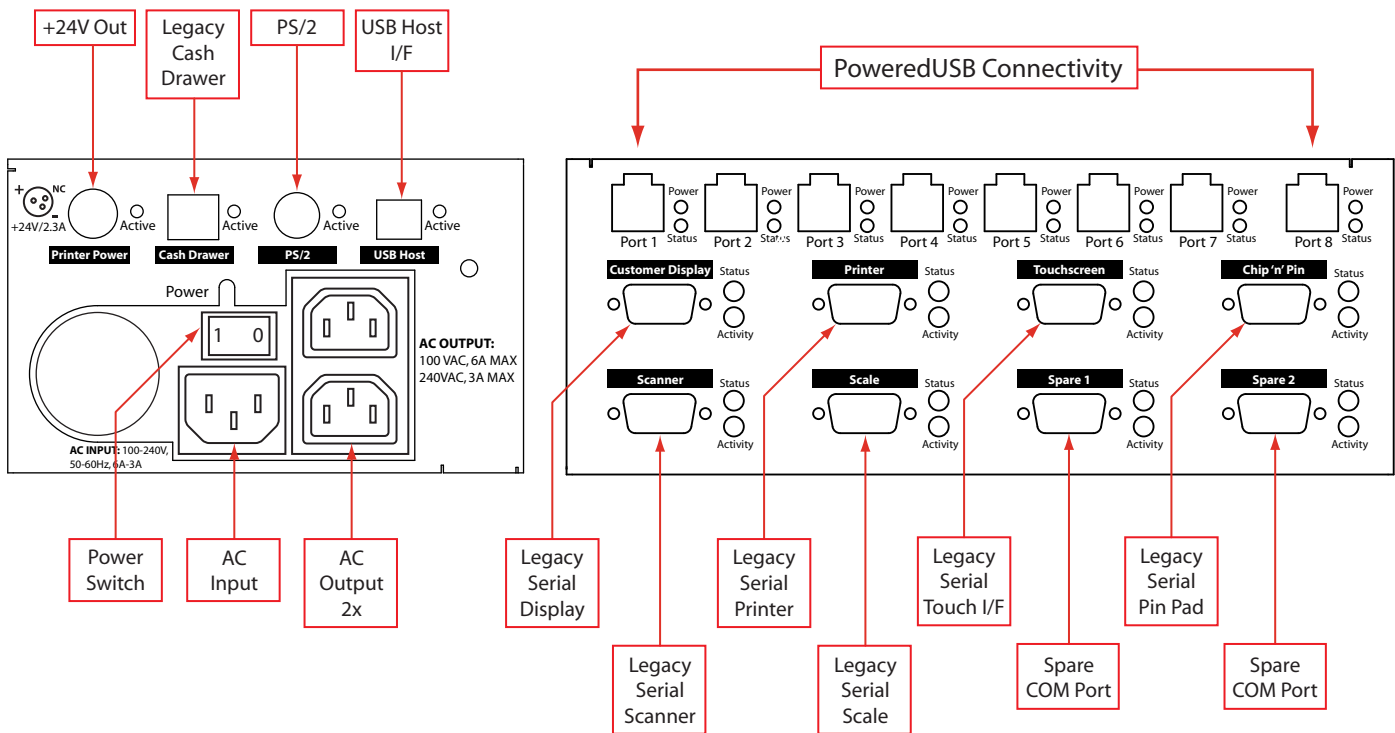
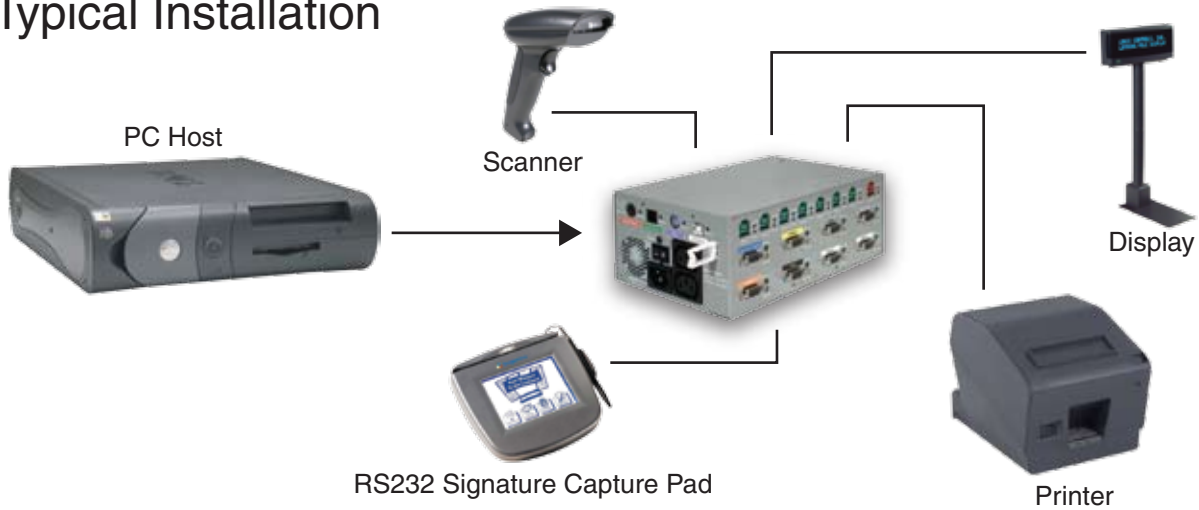

License note:

The Powered-USB controller board contains specific technology covered by a patent held by IBM Corporation. CyberData has obtained a license from IBM that permits CyberData Corporation, among other things, to make or sell products that incorporate this technology. The license also permits these products to be resold by an entity after they have been initially sold by CyberData.